

Physics
Standard level
Paper 1

Tuesday 8 November 2016 (morning)

45 minutes

Instructions to candidates

- Do not open this examination paper until instructed to do so.
- Answer all the questions.
- For each question, choose the answer you consider to be the best and indicate your choice on the answer sheet provided.
- A clean copy of the **physics data booklet** is required for this paper.
- The maximum mark for this examination paper is **[30 marks]**.

1. A boy jumps from a wall 3 m high. What is an estimate of the change in momentum of the boy when he lands without rebounding?
 - A. $5 \times 10^0 \text{ kg m s}^{-1}$
 - B. $5 \times 10^1 \text{ kg m s}^{-1}$
 - C. $5 \times 10^2 \text{ kg m s}^{-1}$
 - D. $5 \times 10^3 \text{ kg m s}^{-1}$

2. Light of wavelength 400 nm is incident on two slits separated by $1000 \mu\text{m}$. The interference pattern from the slits is observed from a satellite orbiting 0.4 Mm above the Earth. The distance between interference maxima as detected at the satellite is
 - A. 0.16 Mm.
 - B. 0.16 km.
 - C. 0.16 m.
 - D. 0.16 mm.

3. A car moves north at a constant speed of 3 m s^{-1} for 20 s and then east at a constant speed of 4 m s^{-1} for 20 s. What is the average speed of the car during this motion?
 - A. 7.0 m s^{-1}
 - B. 5.0 m s^{-1}
 - C. 3.5 m s^{-1}
 - D. 2.5 m s^{-1}

4. An object of weight W is falling vertically at a constant speed in a fluid. What is the magnitude of the drag force acting on the object?
- A. 0
 - B. $\frac{W}{2}$
 - C. W
 - D. $2W$
5. An object, initially at rest, is accelerated by a constant force. Which graphs show the variation with time t of the kinetic energy and the variation with time t of the speed of the object?

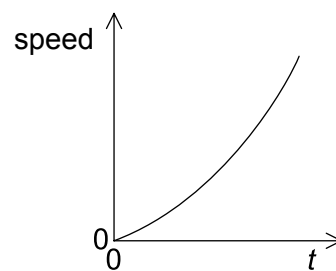
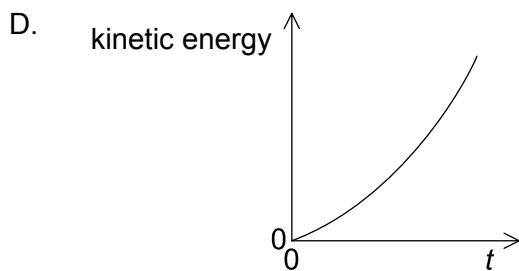
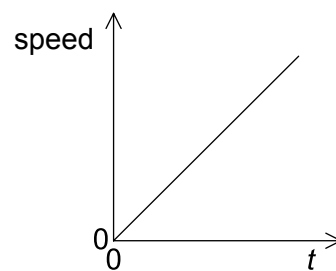
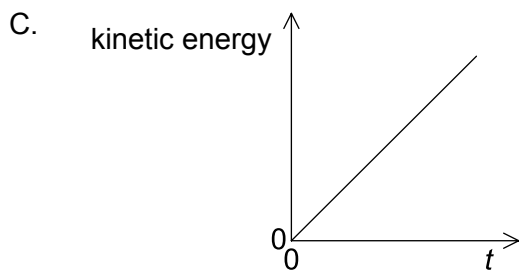
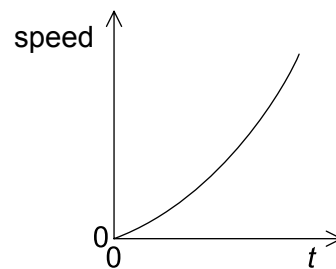
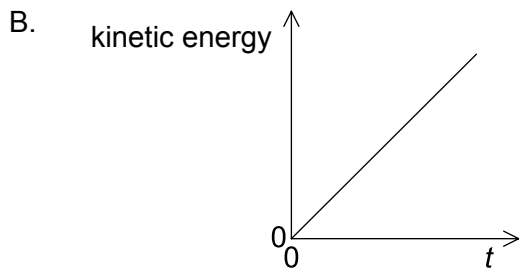
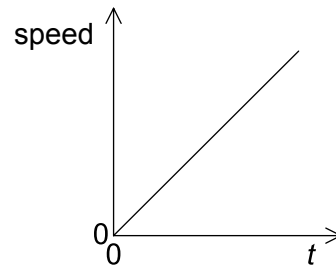
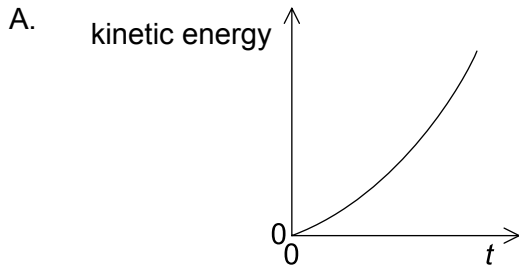

Turn over

6. Two stationary objects of mass 1 kg and 2 kg are connected by a thread and suspended from a spring.

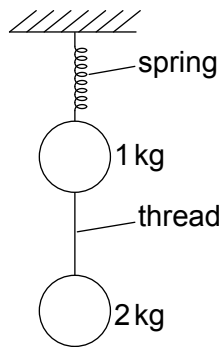

The thread is cut. Immediately after the cut, what are the magnitudes of the accelerations of the objects in terms of the acceleration due to gravity g ?

	Acceleration of 1 kg object	Acceleration of 2 kg object
A.	$3g$	$2g$
B.	$2g$	$2g$
C.	$3g$	$1g$
D.	$2g$	$1g$

7. A student of weight 600 N climbs a vertical ladder 6.0 m tall in a time of 8.0 s. What is the power developed by the student against gravity?
- A. 22 W
 - B. 45 W
 - C. 220 W
 - D. 450 W

8. A ball of mass m strikes a vertical wall with a speed v at an angle of θ to the wall. The ball rebounds at the same speed and angle. What is the change in the magnitude of the momentum of the ball?

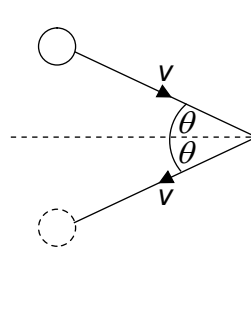

- A. $2mv \sin \theta$
B. $2mv \cos \theta$
C. $2mv$
D. zero
9. Two objects m_1 and m_2 approach each other along a straight line with speeds v_1 and v_2 as shown. The objects collide and stick together.



What is the total change of linear momentum of the objects as a result of the collision?

- A. $m_1v_1 + m_2v_2$
B. $m_1v_1 - m_2v_2$
C. $m_2v_2 - m_1v_1$
D. zero

Turn over

10. Energy is supplied at a constant rate to a fixed mass of a material. The material begins as a solid. The graph shows the variation of the temperature of the material with time.

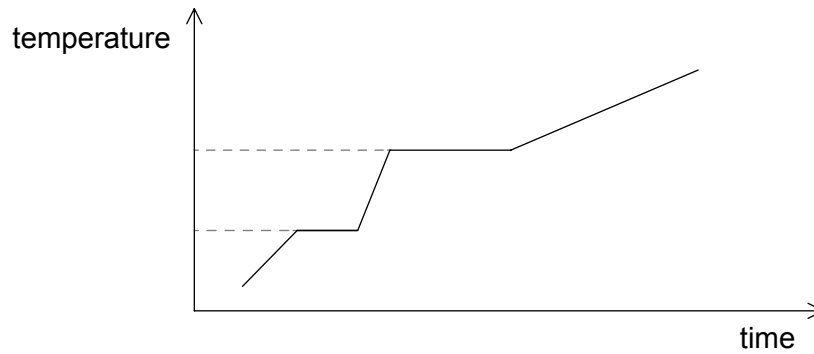

The specific heat capacities of the solid, liquid and gaseous forms of the material are c_s , c_l and c_g respectively. What can be deduced about the values of c_s , c_l and c_g ?

- A. $c_s > c_g > c_l$
- B. $c_l > c_s > c_g$
- C. $c_l > c_g > c_s$
- D. $c_g > c_s > c_l$

11. An ideal gas of N molecules is maintained at a constant pressure p . The graph shows how the volume V of the gas varies with absolute temperature T .

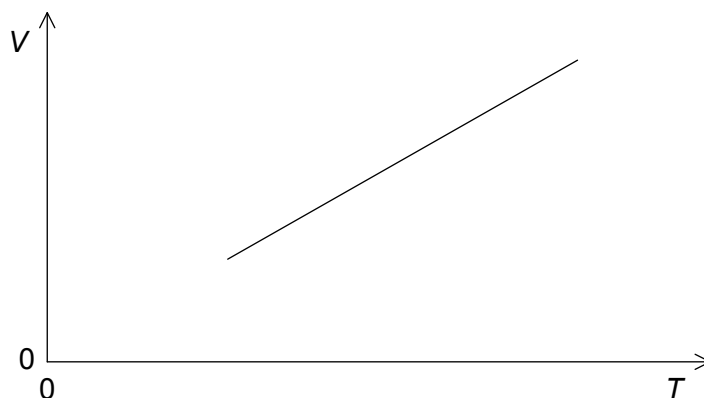

What is the gradient of the graph?

- A. $\frac{N}{p}$
- B. $\frac{NR}{p}$
- C. $\frac{Nk_B}{p}$
- D. $\frac{N}{Rp}$
12. The pressure of a fixed mass of an ideal gas in a container is decreased at constant temperature. For the molecules of the gas there will be a decrease in
- A. the mean square speed.
- B. the number striking the container walls every second.
- C. the force between them.
- D. their diameter.

Turn over

13. A body undergoes one oscillation of simple harmonic motion (shm). What is correct for the direction of the acceleration of the body and the direction of its velocity?
- A. Always opposite
 - B. Opposite for half a period
 - C. Opposite for a quarter of a period
 - D. Never opposite

14. A particle oscillates with simple harmonic motion (shm) of period T . Which graph shows the variation with time of the kinetic energy of the particle?

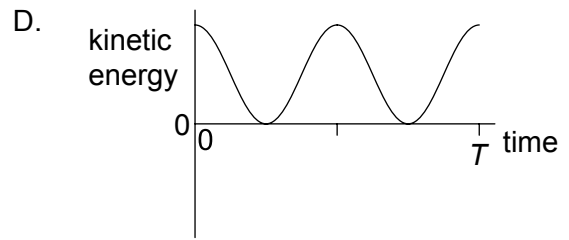
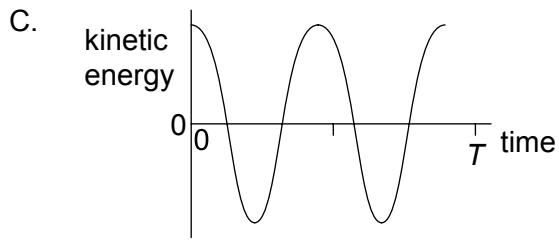
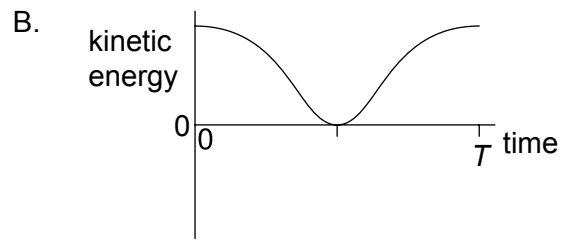
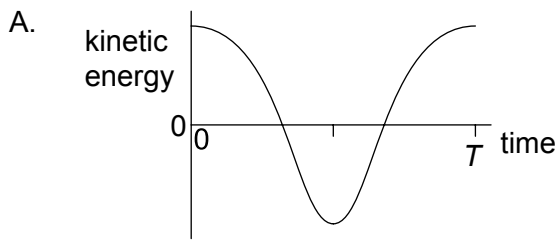

15. A light ray is incident on an air–diamond boundary. The refractive index of diamond is greater than 1. Which diagram shows the correct path of the light ray?

A.

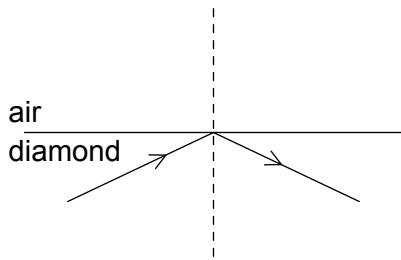

B.

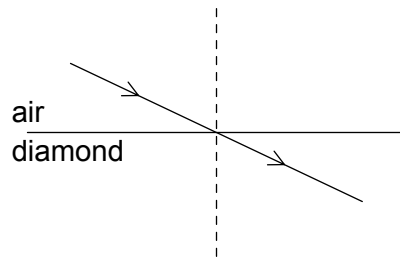

C.

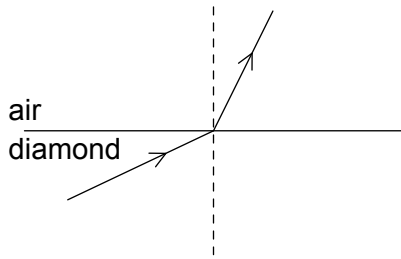

D.

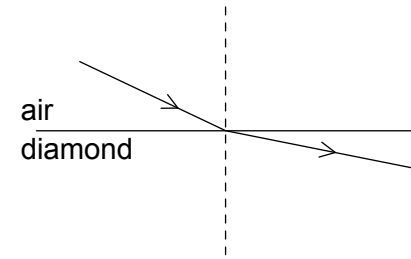

16. A spring XY lies on a frictionless table with the end Y free.

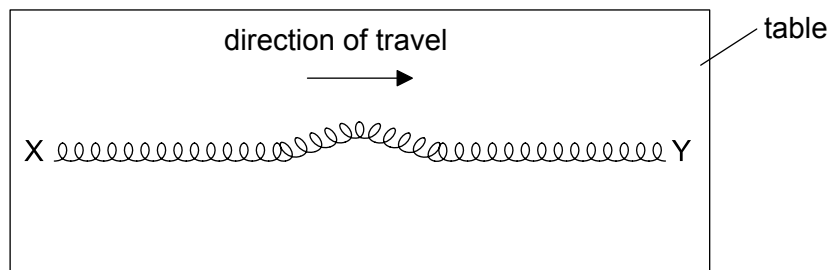

A horizontal pulse travels along the spring from X to Y. What happens when the pulse reaches Y?

- A. The pulse will be reflected towards X and inverted.
- B. The pulse will be reflected towards X and not be inverted.
- C. Y will move and the pulse will disappear.
- D. Y will not move and the pulse will disappear.

Turn over

17. A student stands a distance L from a wall and claps her hands. Immediately on hearing the reflection from the wall she claps her hands again. She continues to do this, so that successive claps and the sound of reflected claps coincide. The frequency at which she claps her hands is f . What is the speed of sound in air?

- A. $\frac{L}{2f}$
- B. $\frac{L}{f}$
- C. Lf
- D. $2Lf$

18. A $-5\mu\text{C}$ charge and a $+10\mu\text{C}$ charge are a fixed distance apart.

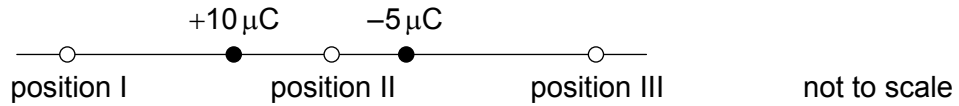

Where can the electric field be zero?

- A. position I only
- B. position II only
- C. position III only
- D. positions I, II and III

19. An electrical circuit is shown with loop X and junction Y.

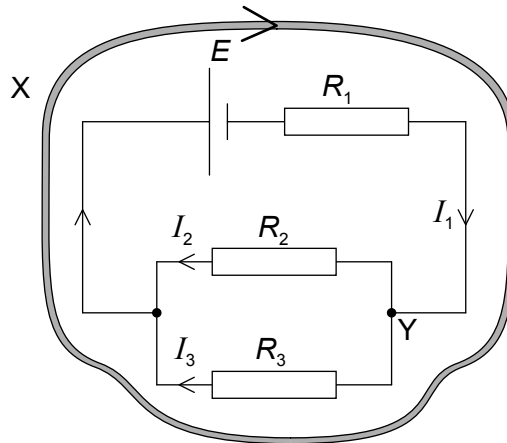

What is the correct expression of Kirchhoff's circuit laws for loop X and junction Y?

	Loop X	Junction Y
A.	$-E = I_1 R_1 + I_3 R_3$	$I_1 = I_2 + I_3$
B.	$-E = I_1 R_1 + I_3 R_3$	$I_1 + I_2 = I_3$
C.	$E = I_1 R_1 - I_3 R_3$	$I_1 = I_2 + I_3$
D.	$E = I_1 R_1 - I_3 R_3$	$I_1 + I_2 = I_3$

Turn over

20. A cell of emf 4 V and negligible internal resistance is connected to three resistors as shown. Two resistors of resistance 2Ω are connected in parallel and are in series with a resistor of resistance 1Ω .

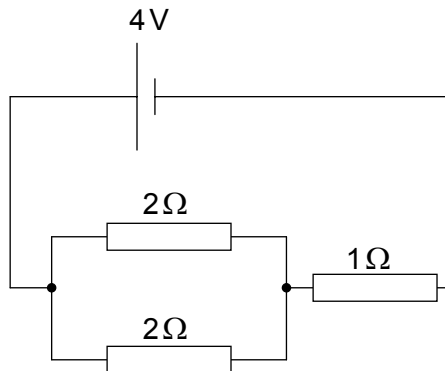

What power is dissipated in one of the 2Ω resistors and in the whole circuit?

	Power dissipated in 2Ω resistor / W	Power dissipated in whole circuit / W
A.	2	6
B.	1	6
C.	0.5	8
D.	2	8

21. A wire carrying a current I is at right angles to a uniform magnetic field of strength B . A magnetic force F is exerted on the wire. Which force acts when the same wire is placed at right angles to a uniform magnetic field of strength $2B$ when the current is $\frac{I}{4}$?

- A. $\frac{F}{4}$
 B. $\frac{F}{2}$
 C. F
 D. $2F$

22. An object at the end of a wooden rod rotates in a vertical circle at a constant angular velocity. What is correct about the tension in the rod?
- A. It is greatest when the object is at the bottom of the circle.
 - B. It is greatest when the object is halfway up the circle.
 - C. It is greatest when the object is at the top of the circle.
 - D. It is unchanged throughout the motion.

23. On Mars, the gravitational field strength is about $\frac{1}{4}$ of that on Earth. The mass of Earth is approximately ten times that of Mars.

What is $\frac{\text{radius of Earth}}{\text{radius of Mars}}$?

- A. 0.4
 - B. 0.6
 - C. 1.6
 - D. 2.5
24. Photons of energy 2.3 eV are incident on a low-pressure vapour. The energy levels of the atoms in the vapour are shown.

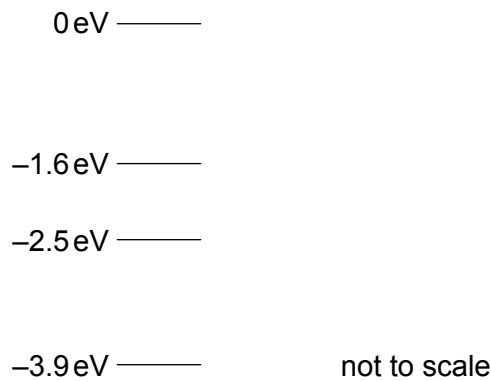

What energy transition will occur when a photon is absorbed by the vapour?

- A. -3.9 eV to -1.6 eV
- B. -1.6 eV to 0 eV
- C. -1.6 eV to -3.9 eV
- D. 0 eV to -1.6 eV

Turn over

25. When an alpha particle collides with a nucleus of nitrogen-14 (${}^{14}_7\text{N}$), a nucleus X can be produced together with a proton. What is X?
- A. ${}^{18}_8\text{X}$
 - B. ${}^{17}_8\text{X}$
 - C. ${}^{18}_9\text{X}$
 - D. ${}^{17}_9\text{X}$
26. The mass defect for deuterium is 4×10^{-30} kg. What is the binding energy of deuterium?
- A. 4×10^{-7} eV
 - B. 8×10^{-2} eV
 - C. 2×10^6 eV
 - D. 2×10^{12} eV
27. As quarks separate from each other within a hadron, the interaction between them becomes larger. What is the nature of this interaction?
- A. Electrostatic
 - B. Gravitational
 - C. Strong nuclear
 - D. Weak nuclear

28. The Sankey diagram represents the energy flow for a coal-fired power station.

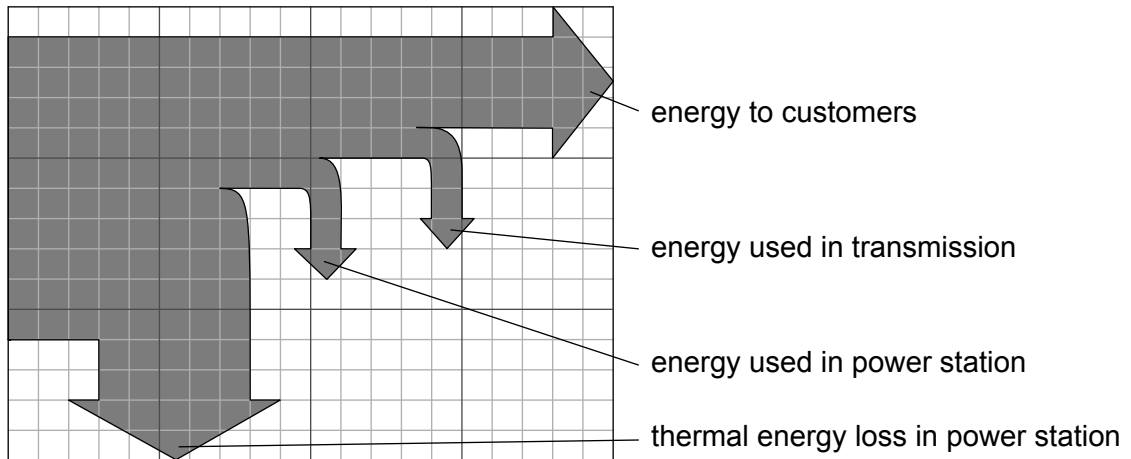

What is the overall efficiency of the power station?

- A. 0.3
 - B. 0.4
 - C. 0.6
 - D. 0.7
29. Which of the following is **not** a primary energy source?
- A. Wind turbine
 - B. Jet Engine
 - C. Coal-fired power station
 - D. Nuclear power station
30. What are the principal energy changes in a photovoltaic cell and in a solar heating panel?

	Photovoltaic cell	Solar heating panel
A.	solar to electrical	solar to thermal
B.	solar to thermal	solar to thermal
C.	solar to electrical	electrical to thermal
D.	solar to thermal	electrical to thermal